

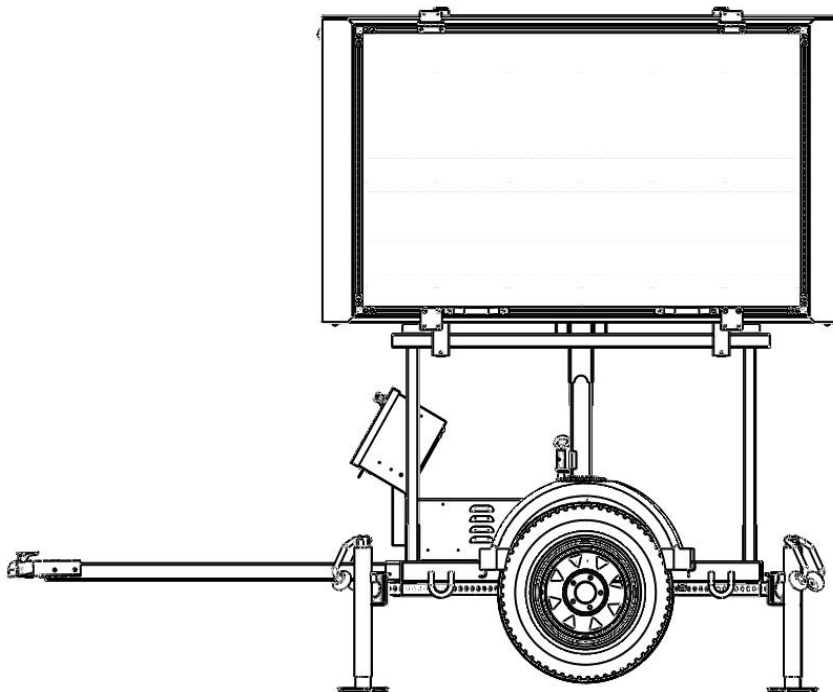

PRODUCT SPECIFICATION

SOLAR MESSAGE CENTER MODEL SMC-5000



1.0 INTRODUCTION

The SMC5000 Message Center manufactured by Work Area Protection Corp. is a trailer mounted variable message board consisting of LED lamp matrix panels powered by a bank of batteries in order to convey bright, distinctive messages to the public. Varying electronically generated lamp messages and graphics are displayed to highway traffic as advisories or for the purposes of warning and/or control. This message center harvests solar energy via solar panels to maintain a charge on the batteries and contains an onboard computer so that it is autonomous and easy to deploy. The SMC5000 is designed with sufficient energy backup to operate for a period of 17 days without any sun. The solar panel generator array recharges the battery bank at a rate of 2-4 hours sun to one 24 hour period of usage.

The SMC 5000 Message Center is a full matrix style unit - this enhances its versatility. It was conceptualized, designed, and developed for traffic areas where space and size constraints are of concern. It provides maximum visibility to the public while utilizing minimal space.

The SMC5000 is designed to remain operational under inclement weather conditions. All workmanship, materials, and assembly procedures are of quality design. Each component of the unit is adequate for and compatible with all structural and performance requirements of the complete unit.

2.0 FEATURES

2.1 GENERAL

- Raised Height - 131" (3.3m)
- Travel Height - 99" (2.5m)
- Travel Width - 68" (1.73m)
- Length with tongue - 107" (2.72m)
- Length w/out tongue - 55" (1.4m)
- Weight - 850 lbs. (385.5kg)
- Operating Temperature - -29 to +49 degrees C

2.2 MAST

- 360° Full Rotation for optimal viewing angle
 - Includes 8 position locking mechanism
- Zinc plating is used on the mast as an expendable electrode to prohibit corrosion. Zinc-plating is the most efficient method of performing this task while avoiding creating pollution and/or hazardous conditions.
- 3" x 3" square steel tubing
- 2" x 2" square steel tube support frame
- Locking mechanism to secure message board in raised and lowered positions
- Winch mechanism with 1500 lb. capacity provides mechanical advantage for single person deployment

2.3 TRAILER

- Frame
 - Industrial grade steel platform designed for years of dependable service.
 - 2" x 3" 11-gauge steel frame.
 - High quality, oven baked, corrosion-resistant powder coat paint. (Color options available)
 - Mast Pivot Tube - .25" x 5" round carbon steel
 - License plate holder
- Wheels
 - 14" wheels and tires (ST205/75D14 @ Load Range C)
 - Rated for towing at on-highway velocities (65mph).
 - 2,000 lb. (907kg.) capacity axle for enhanced durability
 - 1,400 lb. capacity leaf springs
 - Formed Plastic Fenders
- Leveling Jacks
 - Four leveling jacks
 - Crank Type
 - Heavy-Duty
 - Slide-out (telespar) extensions for enhanced stability.
- Battery Box
 - 14 Gauge Steel
 - Lockable

- Tongue
 - SAE Class 2
 - Rated @ 3500 Lbs
 - 2.5" x 2.5" square tubing
 - 60" overall length
 - 2" ball type trailer hitch
 - Double safety chains in accordance with SAE J684FII
 - Removable and replaceable hitch
 - Pintle ring options available
- Illumination
 - Square red lights for stop, turn, and taillight with reflector on the sides for safety
 - Amber reflector near front on each side

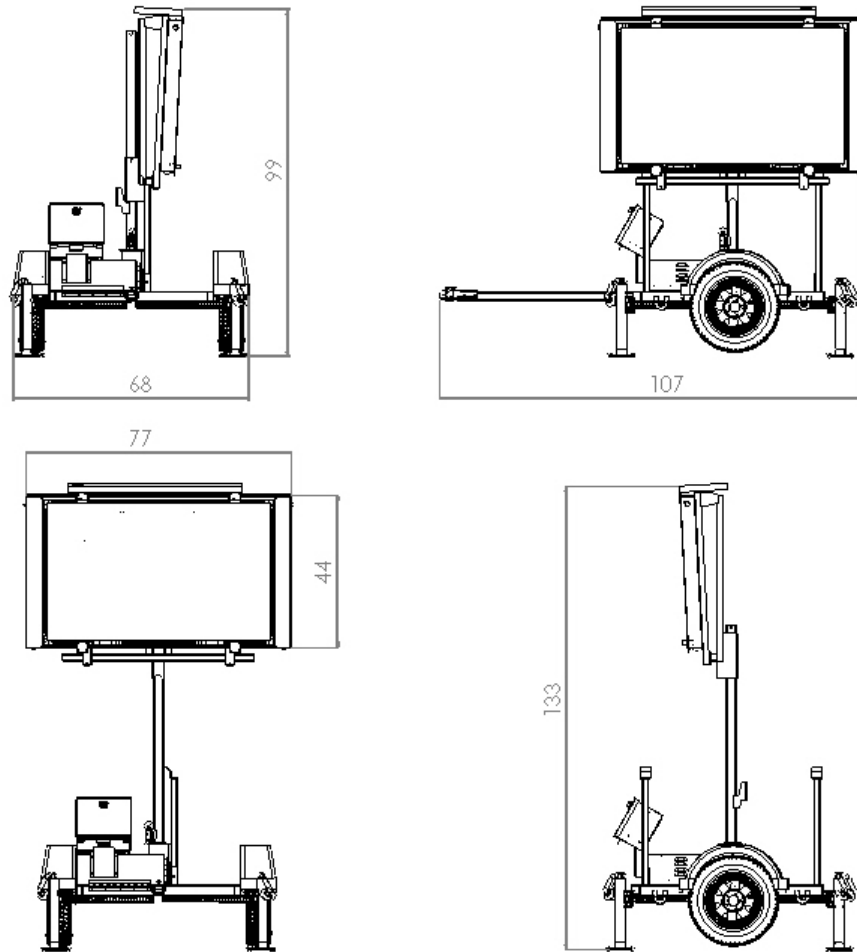

Units in inches

2.4 POWER SYSTEM

- Batteries
 - 4 – 6V Batteries
 - Wired in parallel
 - Lockable, heavy-duty 14 gauge steel weatherproof box
 - Louver array for ventilation
 - Accepts end user supplied padlocks
 - Fully welded construction
 - Charged by solar energy harvesting array
 - Approximately 60 lbs. each
 - 468 amp hours total
- Solar Panel Array
 - High efficiency photovoltaic solar panel
 - 140 Watt minimum
 - Operating Voltage – 12 Volts
 - Provides one day of power requirements in 2-4 hours of sunlight
 - Provides years of service with minimal maintenance
- Charge Controller
 - Series regulator
 - Thermal compensation to regulate charge rate of the battery bank
 - Modular for easy replacement (standard 5/16" nut driver)
 - Low voltage disconnect
 - 11.0 V – 4 Corner Caution (See page 9 graphic_
 - 10.6V - Off
 - AC/DC Battery Charger – 45 Amp

2.5 SYSTEM CONTROL

- On-board self-contained computer
 - NTCIP compliant
 - Display Type - Liquid Crystal
 - Screen Size - 320 x 240 Dot Pixels.
 - Power requirements - 100mA @ 12VDC
 - Processor - ARM Cortex-M4
 - Memory Backup - MRAM/10 Year Life
 - Interfaces - RS232, Ethernet, USB Host
 - Humidity - 95% Non-condensing
 - Temperature - (-25)to 50 degrees Celsius
 - Located in 14 gauge steel, vandal-proof enclosure with key-locking handle
 - Weather-proof keyboard for user originated messages.
- Functions
 - Stores 250 preprogrammed messages for display when called upon by the operator through the keyboard
 - Stores 80 preprogrammed graphic messages
 - Provides 3 levels of password protection
 - Provides control programming to display stored messages by operator control through keyboard entry
 - Provide control for moving arrow display
 - Provide automatic word centering without separate programming
 - Provide programming capability while message is being displayed
 - Includes a scheduling calendar to automatically start and stop the display of messages at predetermined times
 - Provides character board and battery diagnostics

2.6 MESSAGE BOARD

- Features
 - Weather-proof, aluminum construction, assembled to prevent dissimilar metal action from occurring.
 - Hinged display window covered with UV inhibiting polycarbonate to prevent fading.
 - One continuous lamp matrix provides text messages as well as graphic symbols.
 - Projects multiple size characters ranging from 9 to 37 inches.
 - Black background for contrast enhancement.
 - Operator/End User friendly -Modular character boards for easy replacement and maintenance.
 - Under variable light conditions the automatically adjusts its light source so as to meet legibility requirements without being too dim or too intense.
- Specifications
 - Dimensions - 77" width x 44" height x 5" thick
 - Operating Temperature - -55⁰C to 100⁰C
 - Full Matrix Pixels - 1344 (48 pixels wide x 28 pixels high)
 - Pixel (Message) Color - Amber (590nm).
 - Pixel Size - .68" x .68"
 - Bottom of the board is 7 feet above the ground in the raised position per industry regulation.
- Capabilities
 - Provides 250 text, 60 graphic, and 20 arrow board display messages.
 - 100 user-created messages can be stored.
 - Capable of displaying up to six pages in message, with variable timing in 0.1 second increments.

- Text Operations

ABCDEFGHI
IJKLMNOP
QRSTUVWXYZ

font 1

ABCDEF
GHIJKL
MNOPQR

font 2

ABCDE
FGHIJ

font 3

ABCDEFGHIJ
KLMNOPQRS
TUVWXYZ12

font 4

ABCDEFGHIJK
LMNOPQRSTU
VWXYZ1234567
890 !"#%&'*

font 5

ABCDEFGHIJK
LMNOPQRSTU
VWXYZ1234567
890 !"#%&'*

font 6

ABCDEF

font 7

ABCDE

font 8

- Other Functionality

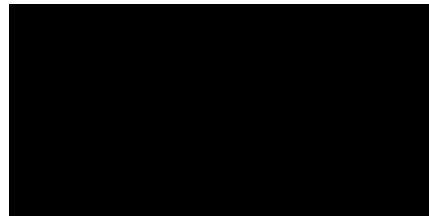
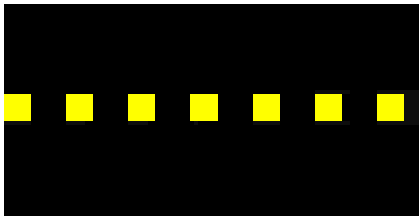
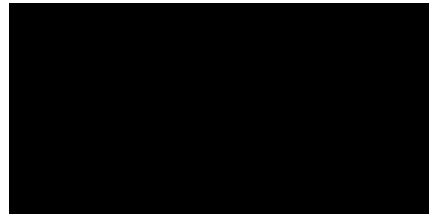
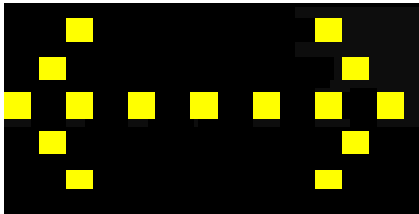
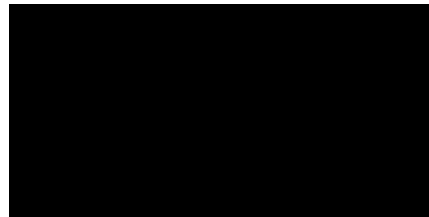
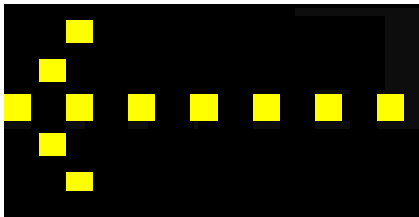
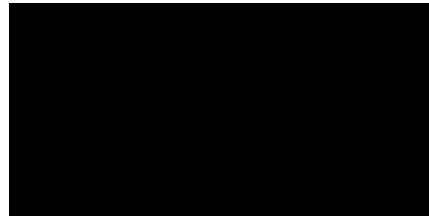
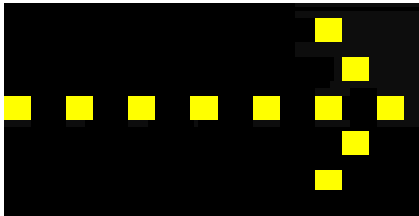
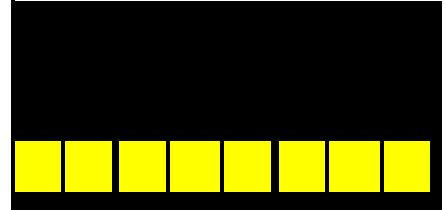
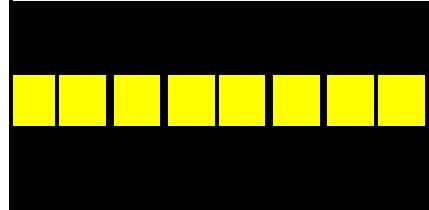
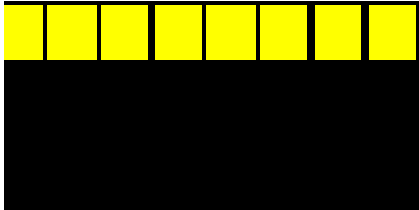
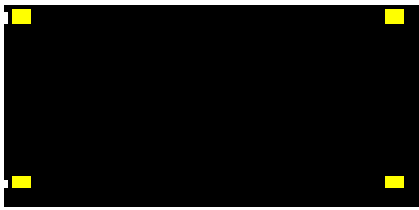

- Other Functionality cont...

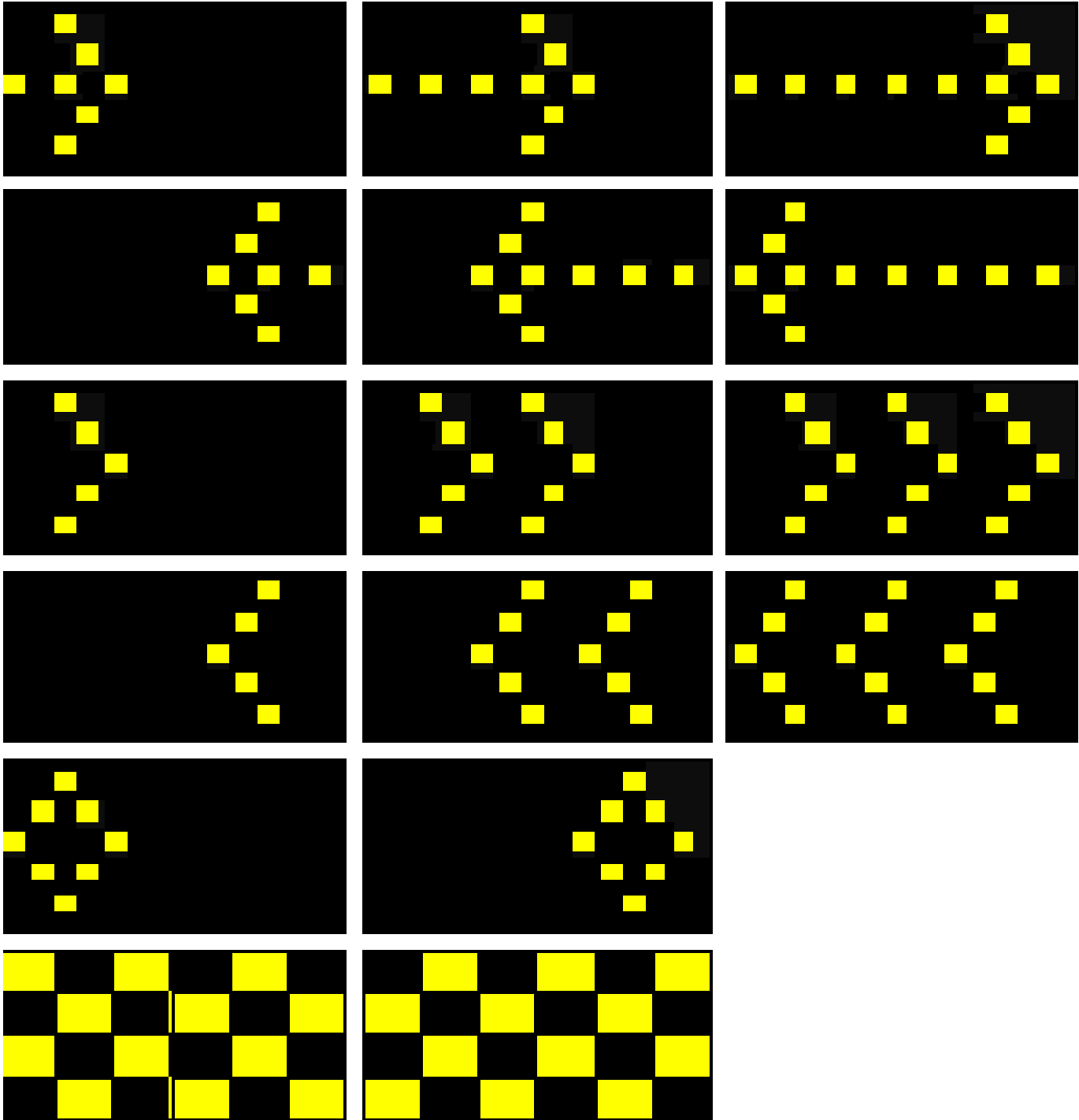

2.7 OPTIONAL EQUIPMENT

- ASTI Internet Based Communications System
 - Verizon Modem – Airlink Pinpoint Modem Only – Serial
 - Verizon Ethernet – Airlink Ethernet Modem (includes Ethernet CPU)
 - AT&T Modem – Airlink Pinpoint Modem Only – Serial
 - AT&T Ethernet – Airlink Ethernet Modem (includes Ethernet CPU)
 - Sprint Modem – Airlink Pinpoint Modem Only – Serial
 - Sprint Ethernet – Airlink Ethernet Modem (includes Ethernet CPU)
 - Enhanced Service – ASTI comm system (includes 1st year cellular service)
 - Base Service – ASTI communication system
- Smart Phone/Handheld Options
 - Android Phone App
 - Modem for Smart Phone Apps – includes 1st year service.
 - MultiController – for Smart Phone Apps only
 - Hand Held Controller (includes MultiController)
 - Hand Held Controller, NTCIP Compliant includes MultiController and CPU 6M
- Radar Options
 - Stalker Radar
 - Houston Radar (with or without data collection)
- Extended Warranty
- Spare Tire – Spare wheel and tire
- Conspicuity Tape – 18 linear feet of 2-inch red/white conspicuity tape
- Alignment Sight – Alignment Device to assist in setup
- Hour Meter
- 6 Pole Cole Hersee Plug
- Electromechanical Lift
- 3" Pintle Hitch
- Bulldog Hitch
- Combo Hitch – 3" Pintle Eye Ring / 2" Ball Combination Hitch
- Vandal Box